



型号 : BZX84B5V1-BZX84B20

稳压二极管/ZENER DIODES

## 主要特性/Features

300mW功率消耗/300mW Power Dissipation

稳压电压为5.1V - 20V/Zener Voltages from 5.1V - 20V

## 应用/Application

## 印字/MARKING 等效电路/Equivalent Circuit

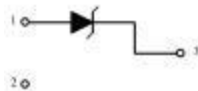
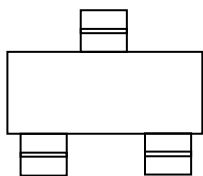



**极限参数/Absolute Maximum Ratings(TA=25°C unless otherwise noted)**

Characteristic	Symbol	Value	Unit
Forward Voltage (Note 2) @ I <sub>F</sub> = 10mA	V <sub>F</sub>	0.9	V
Power Dissipation(Note 1)	P <sub>d</sub>	300	mW
Thermal Resistance from Junction to Ambient	R <sub>θJA</sub>	417	°C/W
Junction Temperature	T <sub>j</sub>	150	°C
Storage Temperature Range	T <sub>stg</sub>	-55~+150	°C

**电性能参数/Electrical Characteristics (TA=25°C unless otherwise noted)**

Type Number	Type Code	Zener Voltage Range (Note 2)				Maximum Zener Impedance (Note 3)			Maximum Reverse Current		Typical Temperature Coefficient @I <sub>ZT</sub> =5 mA	
		V <sub>Z</sub> @I <sub>ZT</sub>			I <sub>ZT</sub>	Z <sub>ZT</sub> @I <sub>ZT</sub>	Z <sub>ZK</sub> @I <sub>ZK</sub>	I <sub>ZK</sub>	I <sub>R</sub>	V <sub>R</sub>	mV/°C	
		Nom(V)	Min(V)	Max(V)	mA	Ω		mA	μA	V	Min	Max
BZX84B5V1	2Z2	5.1	5.00	5.20	5	60	480	1.0	2	2.0	-2.7	1.2
BZX84B5V6	2Z3	5.6	5.49	5.71	5	40	400	1.0	1	2.0	-2.0	2.5
BZX84B6V2	2Z4	6.2	6.08	6.32	5	10	150	1.0	3	4.0	0.4	3.7
BZX84B6V8	2Z5	6.8	6.66	6.94	5	15	80	1.0	2	4.0	1.2	4.5
BZX84B7V5	2Z6	7.5	7.35	7.65	5	15	80	1.0	1	5.0	2.5	5.3
BZX84B8V2	2Z7	8.2	8.04	8.36	5	15	80	1.0	0.7	5.0	3.2	6.2
BZX84B9V1	2Z8	9.1	8.92	9.28	5	15	100	1.0	0.5	6.0	3.8	7.0
BZX84B10	2Z9	10	9.80	10.20	5	20	150	1.0	0.2	7.0	4.5	8.0
BZX84B11	2Y1	11	10.78	11.22	5	20	150	1.0	0.1	8.0	5.4	9.0
BZX84B12	2Y2	12	11.76	12.24	5	25	150	1.0	0.1	8.0	6.0	10.0
BZX84B13	2Y3	13	12.74	13.26	5	30	170	1.0	0.1	8.0	7.0	11.0
BZX84B15	2Y4	15	14.70	15.30	5	30	200	1.0	0.1	10.5	9.2	13.0
BZX84B16	2Y5	16	15.68	16.32	5	40	200	1.0	0.1	11.2	10.4	14.0
BZX84B18	2Y6	18	17.64	18.36	5	45	225	1.0	0.1	12.6	12.4	16.0
BZX84B20	2Y7	20	19.60	20.40	5	55	225	1.0	0.1	14.0	14.4	18.0

Notes:

- Valid provided that device terminals are kept at ambient temperature.
- Tested with pulses, period=5ms,pulse width =300μs.
- f=1kHz.



成品外观尺寸/SOT-23 Package Information

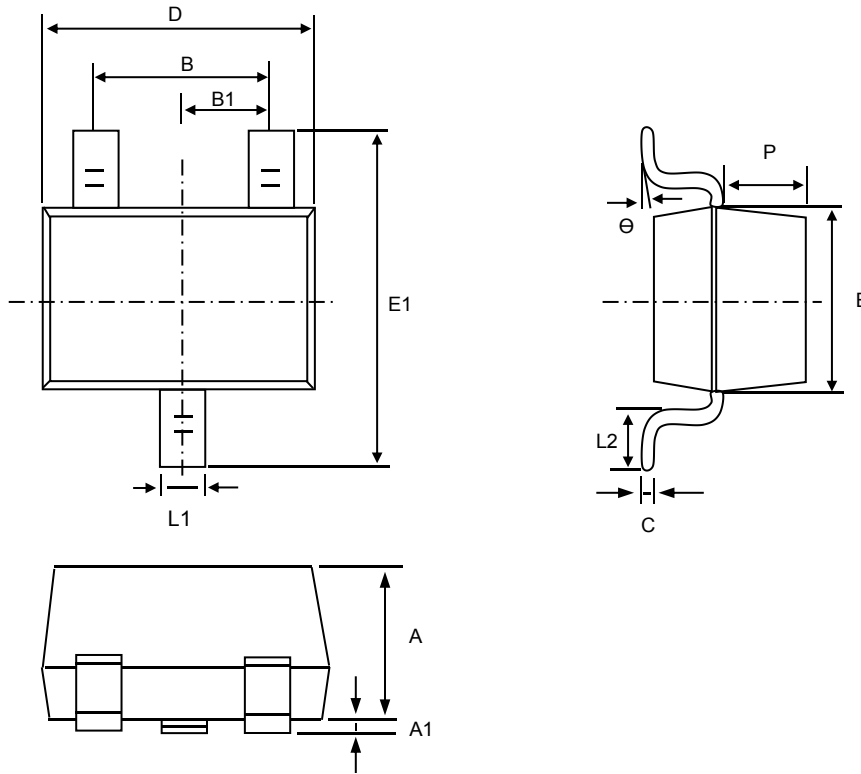

Symbol	Dim in mm		
	Min	Nor	Max
A	0.900	1.000	1.100
A1	0.000	0.050	0.100
L1	0.350	0.400	0.500
C	0.100	0.110	0.120
D	2.800	2.900	3.000
E	1.250	1.300	1.350
E1	2.250	2.400	2.550
B	1.800	1.900	2.000
B1	0.950TPY.		
L2	0.200	0.350	0.450
P	0.550	0.575	0.600